



BUZKAP 1941



CREMONA

arnas

NÖRDUSS

Vento
DONDURMA

Classico

Classico SLIM



STANDART ÜRÜNLER





Kurucumuz Kurken MİRZAHANYAN

1923 - 2009



BUZKAP & DONDURMA

1941 yılından beri soğutma alanında faaliyet gösteren **BUZKAP SOĞUTMA** tarihinden gelen eşsiz tecrübe ve bilgi mirasına ek olarak günümüze kadar ticari soğutma sektöründeki birçok yeniliği de ülkemize taşımıştır.

1980 li yıllarda ilk defa, camlı dondurma teşhir reyonu, salamurasız kapalı reyon ve Dondurmatik ürünleri ile sektöre öncülük etmiştir.

Kilometre taşları arasına İtalyan Bravo firması ile yaptığı işbirliğini ekleyen

BUZKAP SOĞUTMA Dondurmatik ürünlerindeki başarı çalışmaları ile 1990 ılı yıllara gelmiştir. Dünya genelinde yaygınlaşan endüstriyel gıda gelişmelerinden olumsuz olarak etkilenen dondurma sektörü, yerel üreticilerin atakları ve soğutma sektöründeki başarılı

çalışmalar ile 2000 li yıllarda tekrar hareket kazanmıştır.

Ülkemizdeki dondurma tüketimi sert Maraş usulü ve endüstriyel dondurma tüketimi ile dünya genelinin çok gerisinde olmasına rağmen;

Gerçek İtalyan dondurması **GELATO** ile dondurma piyasası yeni bir iş hacmi kazanmıştır.

İşte tam da bu büyüyen pazarda;

Dondurma üretimi, pastörizasyon, dondurma muhafazası, dondurma teşhir reyonları ve pastane tasarımları ile üretimden satışa kadar yurt içi ve yurt dışı geniş satış ağı kanalıyla sektörün hizmetindedir.

YENİ

CREMONA

1995'den beri ürettiğimiz iki sıralı dondurma reyonu tüm bilgi ve deneyimimizle yenilenmiş ve beğeninize sunulmuştur.

Deluxe pasta reyonumuz ile uyumludur.

Teknik Özellikler

Model	CR12	CR18	CR24
Ölçüler	112x114x130 cm	163x114x130 cm	214x114x130 cm
Küvet sayısı	12	18	24
Geniş küvet sayısı	8	12	16
Kompresör	2 hermetik	2 hermetik	1 yarı hermetik
Elektrik gücü	1500W	2000W	2500W
Besleme gücü	220 V / 50 Hz	220 V / 50 Hz	380 V / 50 Hz
Ağırlık	275 kg	445 kg	535 kg

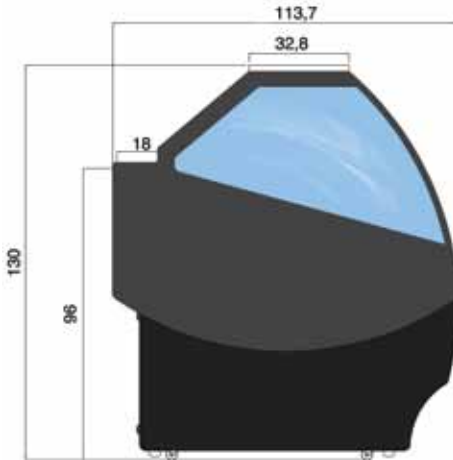

CR18



YENI

CREMONA



CR12





CR24



arnas

Arnas, post modern çizgisi ile dükkanınıza değer katar.

Arnas modelimiz dondurmanın yanında waffle, pasta ve çikolata olarak da üretilir

Teknik Özellikler

Model	A12	A18	A24
Ölçüler	113x112x122 cm	163x112x122 cm	213x112x122 cm
Küvet sayısı	12	18	24
Geniş küvet sayısı	8	12	16
Kompresör	2 hermetik	2 hermetik	1 yarı hermetik
Elektrik gücü	1500W	2000W	2500W
Besleme gücü	220 V / 50 Hz	220 V / 50 Hz	380 V / 50 Hz
Ağırlık	285 kg	455 kg	545 kg

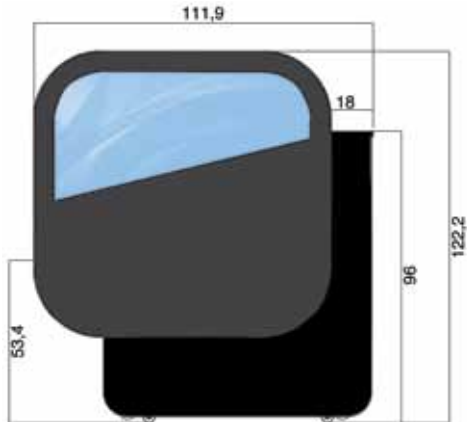

A18



arnas



A18



A24





Nordus modelimiz dondurmanın yanında waffle, pasta ve çikolata olarak da üretilir

Dondurmaya en yakın bakış açısını veren Nordus, tasarlandığı günden itibaren yüksek beğeni ile mağazalarda yer almaktadır.

Teknik Özellikler

Model	N12	N18	N24
Ölçüler	113x116x125 cm	163x116x125 cm	213x116x125 cm
Küvet sayısı	12	18	24
Geniş küvet sayısı	8	12	16
Kompresör	2 hermetik	2 hermetik	1 yarı hermetik
Elektrik gücü	1500W	2000W	2500W
Besleme gücü	220 V / 50 Hz	220 V / 50 Hz	380 V / 50 Hz
Ağırlık	275 kg	445 kg	535 kg

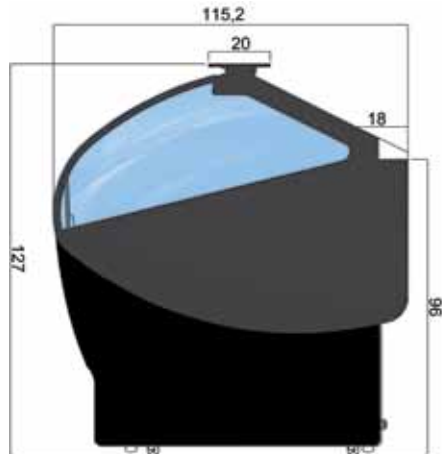



NORDUS





NORDUS





Vento

DONDURMA

Vento modelimiz dondurmanın yanında waffle, pasta ve ikolata olarak da retilir

Vento ada izgilere uygun Őekilde tasarlanmıŐtır. Eklene ara raf ile kup bardaklarına ilk olarak özm sunmuŐtur.

Teknik Özellikler

Model	V12	V18	V24
Ölüler	113x117x141 cm	163x117x141 cm	213x117x141 cm
Kvet sayısı	12	18	24
GeniŐ kvet sayısı	8	12	16
Kompresr	2 hermetik	2 hermetik	1 yarı hermetik
Elektrik gc	1500W	2000W	2500W
Besleme gc	220 V / 50 Hz	220 V / 50 Hz	380 V / 50 Hz
Ağırlık	305 kg	480 kg	585 kg

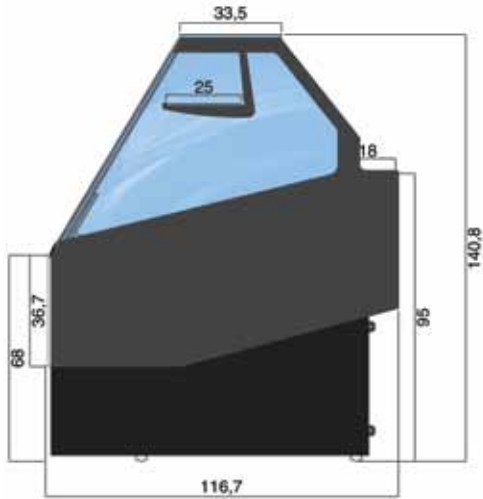



Vento
DONDURMA

V24



Vento
PASTA

V24



Classico

Saydırlık & sadelik

Teknik Özellikler

Model	CL12	CL18	CL24
Ölçüler	113x108x124 cm	163x108x124 cm	213x108x124 cm
Küvet sayısı	12	18	24
Geniş küvet sayısı	8	12	16
Kompresör	2 hermetik	2 hermetik	1 yarı hermetik
Elektrik gücü	1500W	2000W	2500W
Besleme gücü	220 V / 50 Hz	220 V / 50 Hz	380 V / 50 Hz
Ağırlık	275 kg	445 kg	535 kg

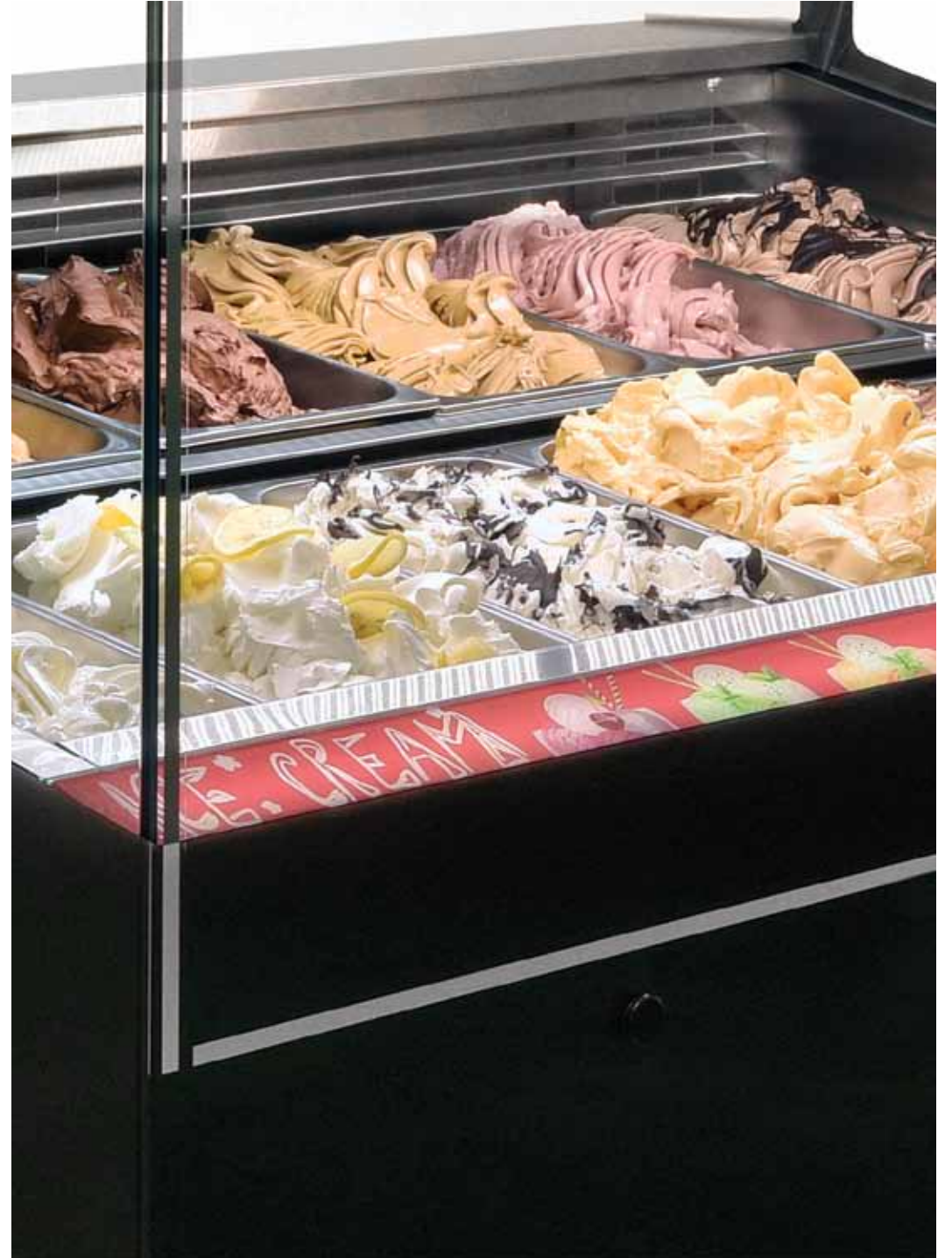
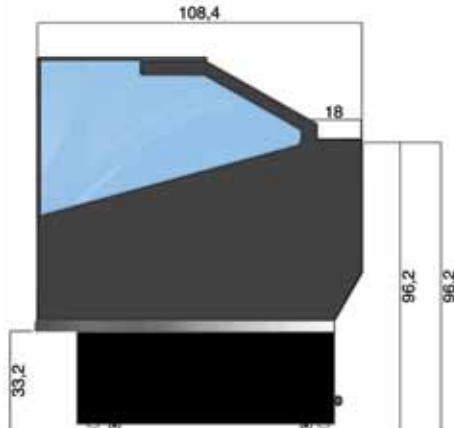



Classico SLIM

Saydamlık - sadelik - incelik

Teknik Özellikler

Model	CLS6	CLS9	CLS12	CLS15
Ölçüler	112x69x125 cm	123x85x131 cm	158x85x131 cm	194x85x131 cm
Küvet sayısı	6	9	12	15
Uzun Küvet Sayısı		6	9	11
Kompresör	1 hermetik	2 hermetik	2 hermetik	2 hermetik
Elektrik gücü	1000W	1500W	2000W	2500W
Besleme gücü	220 V / 50 Hz	220 V / 50 Hz	380 V / 50 Hz	380 V / 50 Hz
Ağırlık	208 kg	240 kg	290 kg	340 kg

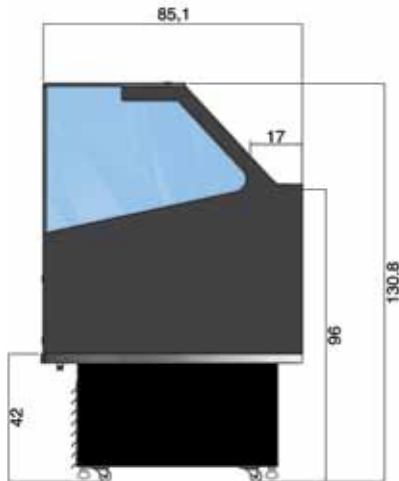

CLS 6



**CLS 6
LONG**



CLS 15





Küçük alanda düşük enerji tüketimi ile en iyi muhafaza ve satış.

Teknik Özellikler

Model	RD4	RD6	RD8	RDB-4
Ölçüler	87x85x125 cm	113x85x125 cm	136x85x125 cm	136x85x125 cm
Küvet sayısı	4	6	8	4
Kompresör	1 hermetik	1 hermetik	1 hermetik	1 hermetik
Elektrik gücü	1000 W	1200 W	1200 W	1200 W
Besleme gücü	220 V / 50 Hz	220 V / 50 Hz	220 V / 50 Hz	220 V / 50 Hz
Ağırlık	150 kg	165 kg	180 kg	195 kg

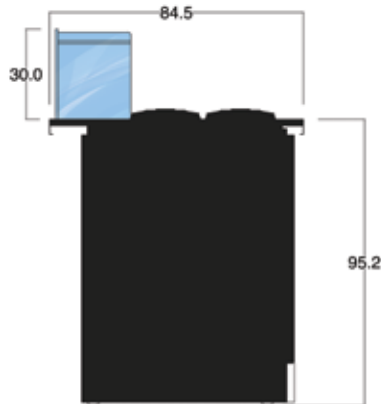



RD4



RD6



RD8





RD 8



cattabriga

DONDURMA DÜNYASININ EFSANESİ

Tüm geleneksel dondurma çeşitleri için yüksek kalite.



EFFE 6B





YATAY TİP DONDURMA YAPICILAR

Tüm dondurma çeşitleri için kolay ve güvenilir kullanım.

cattabriga



Stargel 4



Multifreeze PRO
8 - 12 - 18



Stargel PRO
5 - 8 - 12





PASTÖRİZATÖRLER

Yüksek hijyen standartlarında güvenilir ve kolay kullanılabilir pastörizatörler.

cattabriga



PSK PRO 60/125



EASYMIX 60





KOMBİNE MAKİNALAR

Pastörizatör ve yatay tip dondurma yapıcı tek makinada.



COMPACTA 4



COMPACTA 8



COMPACTA 12





KREMA MAKİNALAR

cattabriga



CREMOMATIC 60



MASTERCHEF 20



EASYFREEZE 2000



TECFRIGO

SET ÜSTÜ DONDURMA TEŞİR REYONLARI



MICROGEL 4
107,2x56x46,7 cm



MICROGEL 2
72,2x56x46,7 cm

MICROGEL 3
89,7x56x46,7 cm

-20°C



ICEPOINT 2
47.5x75x42cm



ICEPOINT 3
64,7x71,7x38 cm





-22°C



KHALIFA 450 BTQ-BIS
71x70x191cm

-22°C



KHALIFA 650 BTQ-BIS
91x70x191cm

-22°C



h:191cm



MUSA 120 R
(+4/+10)
55,1x48,5x106 cm

MUSA 120 BTV
(-10/-21)
55,1x48,5x106 cm

h:109cm



GOLOSO
43x40x109cm



ARG 40



ŞOKLAMA -40°C



BCB 3

ŞOKLAMA

-40°C



BCB 5



BCB 10



BCB 15

STANDART ÜRÜNLER

KP



STANDART ÜRÜNLER

CN



STANDART ÜRÜNLER

SP

Başta içecek olmak üzere; sandvic, salata ve self servis ürünler için kullanışlıdır.

Teknik Özellikler

Model	SP50/80	SP50/100	SP50/130	SP50/160
Ölçüler	80x50x195,5 cm	100x50x195,5 cm	130x50x195,5 cm	160x50x195,5 cm
Kompresör	3/4 HP	1 HP	1.3 HP	1.5 HP
Elektrik gücü	1700 W	1900 W	2250 W	2400 W
Besleme gücü	220V/50 Hz	220V/50 Hz	220V/50 Hz	220V/50 Hz
Ağırlık	130 kg	160 kg	215 kg	255 kg

Teknik Özellikler

Model	SP60/80	SP60/100	SP60/130	SP60/160
Ölçüler	80x63x195,5 cm	100x63x195,5 cm	130x63x195,5 cm	160x63x195,5 cm
Kompresör	3/4 HP	1 HP	1.3 HP	1.5 HP
Elektrik gücü	1700 W	1900 W	2250 W	2400 W
Besleme gücü	220V/50 Hz	220V/50 Hz	220V/50 Hz	220V/50 Hz
Ağırlık	155 kg	195 kg	250 kg	305 kg



REYON DETAYLARI



h:12

h:8

h:12

h:10

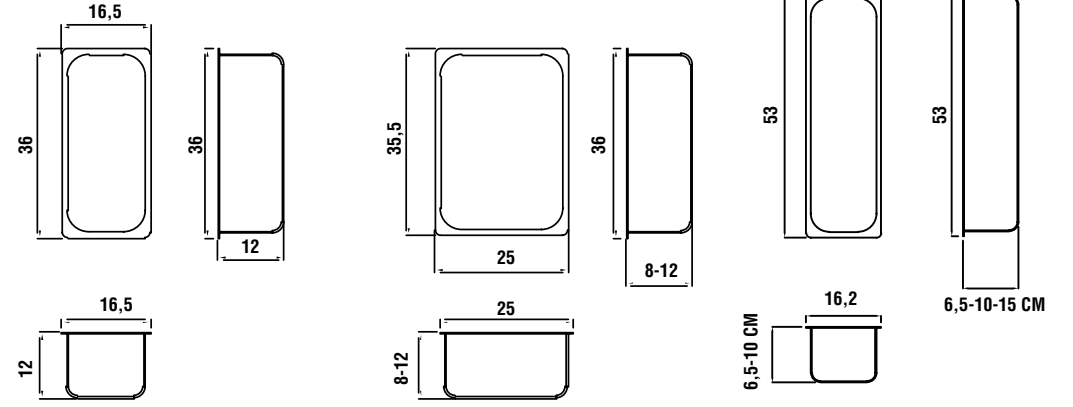

12'li Reyon Kvet Yerleřimi

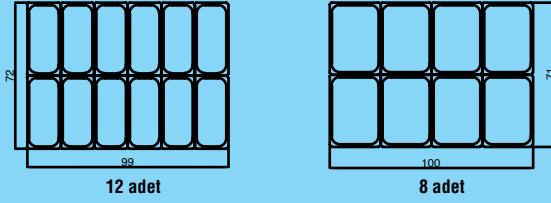

12 adet

8 adet

6'lı Reyon Kvet Yerleřimi

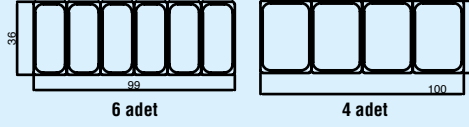

6 adet

4 adet

9'lu Reyon Kvet Yerleřimi

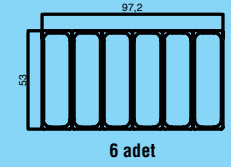

6 adet

18'li Reyon Kvet Yerleřimi

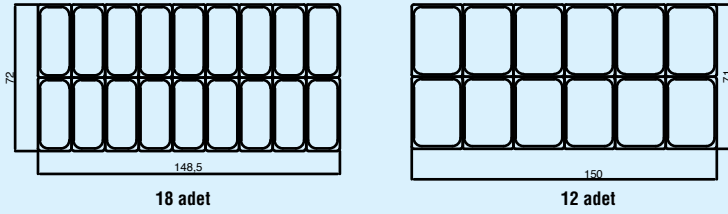

18 adet

12 adet

9'lu Reyon Kvet Yerleřimi

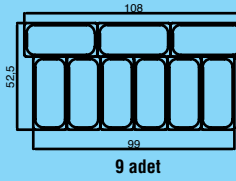

9 adet

12'li Reyon Kvet Yerleřimi

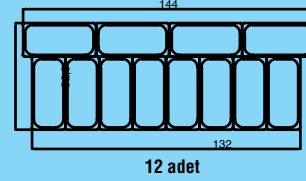

12 adet

12'li Reyon Kvet Yerleřimi

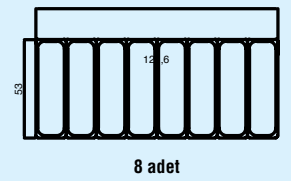

8 adet

24'l Reyon Kvet Yerleřimi

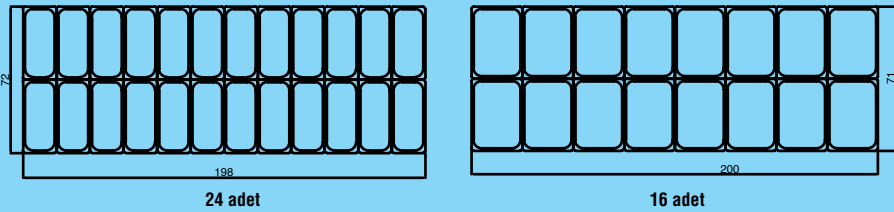

24 adet

16 adet

15'li Reyon Kvet Yerleřimi

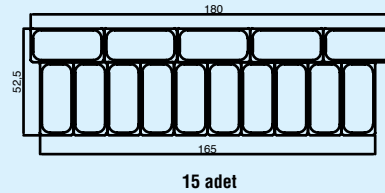

15 adet

15'li Reyon Kvet Yerleřimi

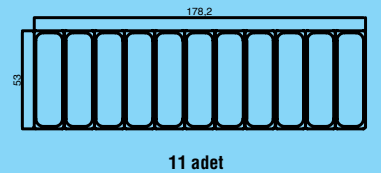

11 adet

PASTÖRİZATÖR İLE TAZE DONDURMA İMALAT HATTI

cattabriga

BUZKAP
1941

GEMM®



cattabriga

PSK KEL 1255 AMP PASTÖRİZATÖR

Kg (min-max) : 40 - 120
Güç : 14 kW
Akım : 400/50/3
Soğutma : Su
Ağırlık : 255 kg
Boyut : 64x88x107 cm

cattabriga

TMK 65+65 PRO BEKLETME

Kg (min-max) : 40 - 120
Güç : 2,5 kW
Akım : 220/50/1
Soğutma : Su
Ağırlık : 187 kg
Boyut : 70x85x103 cm

cattabriga

MULTIFREEZE 18 PRO DONDURMA YAPICI

Kg (min-max) : 3 - 18
Kapasite (saat) : 108 kg
Güç : 12 kW
Akım : 400/50/3
Soğutma : Su
Ağırlık : 390 kg
Boyut : 60x84x137 cm

cattabriga

BCB 05 ŞOKLAMA

Kapasite : 5 x GN 1/1
5 x 60*40 cm
Güç : 1,05 kW
Akım : 230/50/1
Otomatik defrost
Ağırlık : 105 kg
Boyut : 80x70x90 cm

cattabriga

ARG 40 DONDURMA MUHAFAZA

Kapasite : 800 lt. 54 adet x 5 lt
Güç : 0,79 kW
Akım : 230/50/1
Derece : - 22 / -10°C
Ağırlık : 210 kg
Boyut : 78x108x211 cm

KOMBİNE MAKİNE İLE TAZE DONDURMA İMALAT HATTI

cattabriga

BUZKAP
1941

GEMM



cattabriga

COMPACTA VARIO 8 PRO

Kg (min-max) : 1,5-8
Kapasite (saat) : 60 kg
Güç : 9 kW
Akım : 400/50/3
Soğutma : Su
Ağırlık : 280 kg
Boyut : 53x70x137 cm

GEMM

BCB 03 ŞOKLAMA

Güç : 0,6 Kw
Akım : 230/50/1
Otomatik Defrost
Ağırlık : 76 kg
Boyut : 80x70x90 cm

GEMM

ARG 40 DONDURMA MUHAFAZA

Kapasite : 1000 lt 54 adet 5 lt
Güç : 1,06 Kw
Akım : 230/50/1
Derece : (-25/-10°C)
Ağırlık : 210 kg
Boyut : 78x108x211 cm

BUZKAP

CREMONA 18

Kapasite : 18 Küvet
Güç : 5 Kw
Akım : 380/50/3
Derece : (-25/-18°C)
Ağırlık : 500 kg
Boyut : 163x117x125 cm

ÖRNEK DONDURMA DÜKKAN ÇALIŞMASI

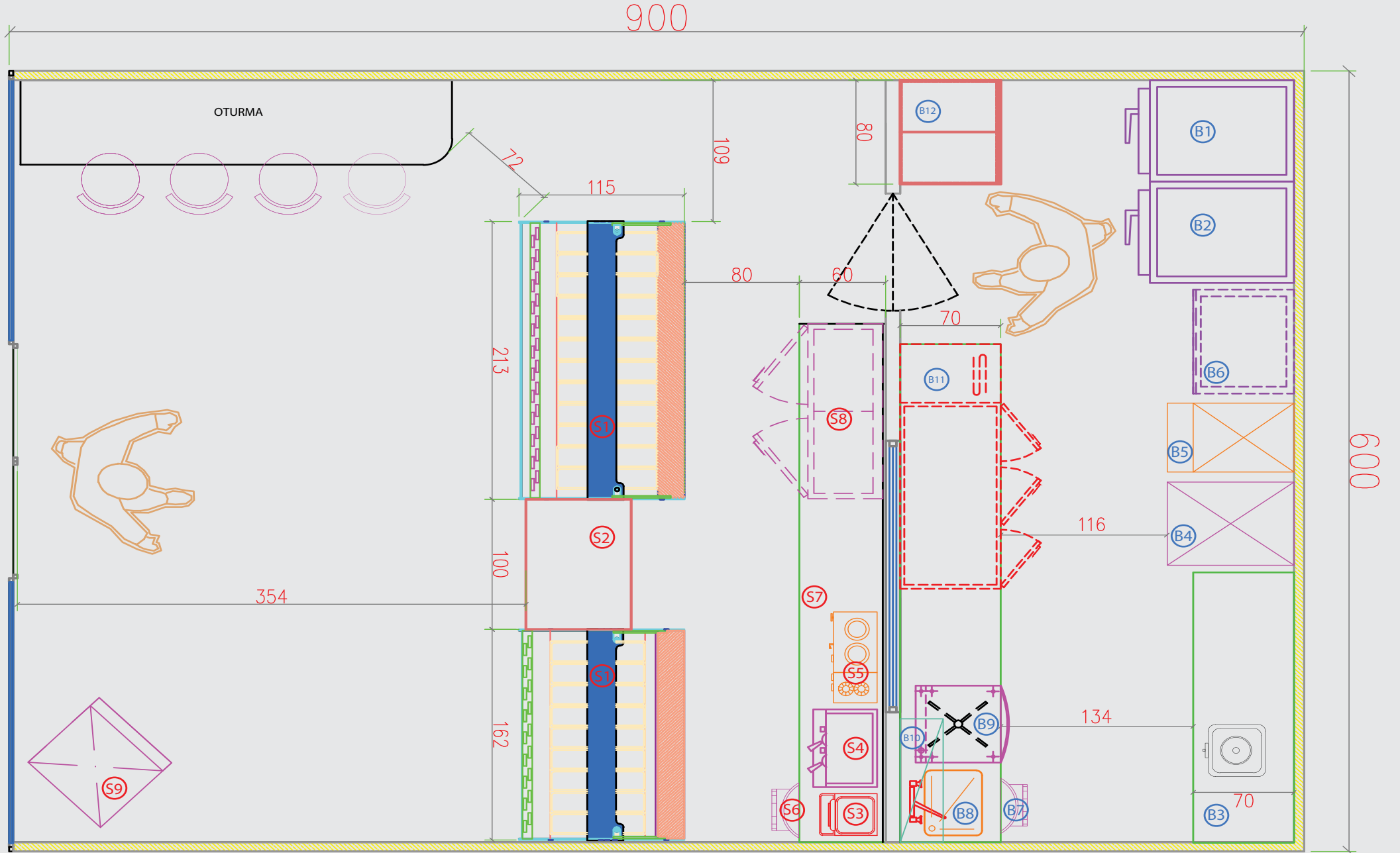

SERVİS BÖLÜMÜ

S1 N24 dondurma	S6 Çöp arabası
S2 Kasa	S7 Mermer tablalı çalışma tezgahı
S3 Şerbetlik	S8 Setaltı içecek dolabı
S4 Kahve makinesi	S9 Khalifa 450 BTQ-BIS Dondurmali pasta 71x70x91cm
S5 Çay makinesi	

BULAŞIKHANE ve HAZIRLIK BÖLÜMÜ

B1 GEMM ARP 40 Dik tip duzdolabı (+4C°) 78x108x212cm	B7 Çöp
B2 GEMM ARG 40 Dondurma muhafaza (-22C°) 78x108x211cm 54 küvet	B8 Eysel çalışma tezgahı
B3 Paslanmaz çalışma tezgahı, altta nötr dolap	B9 Bulaşık makinesi
B4 PSK 125 PRO Pastörizatör 64x88x137cm	B10 Çift sıra duvar rafı
B5 MULTIFREZE 12 Dondurma yapıcı 53x70x137cm	B11 3 kapılı soğuk dolap
B6 GEMM BCB 05 Şoklama 80x70x90cm	B12 Paslanmaz dolap

RETRO KAPAK ve KOVA



OPSİYONEL KAŞIK YIKAMA



REYON KÜVETLERİ





Ortaköy Sanayi Bölgesi Merkez Mahallesi
Atalay Sokak A Blok No:1
Silivri 34570 İstanbul / TURKEY
T+90 212 62326 10 / 3 hat
F+90 212 623 01 84

www.buzkap.com